



UAZ

SINCE 1941

UAZ PICKUP

RELIABLE FOR WORK,
USEFUL FOR HOLIDAY



FOR WORK...

WORK

For important business you need an assistant you can always rely on. The UAZ Pickup, combining reliability and safety with spaciousness and practicality, is just such an assistant.



CONSTRUCTION

Need to deliver heavy building materials quickly? UAZ Pickup is the perfect solution - a spacious cargo compartment bed with a drop side and legendary off-road performance under any conditions.



AND ADVENTURES

FISHING

To reach the prime fishing spots you need a real off-road vehicle. All your fishing tackle, an inflatable boat and your catch will easily fit in the cargo compartment of the UAZ Pickup so you will be sure your cabin is protected.



HUNTING

UAZ Pickup is a helper on your hunt! You can take everything and more. The cargo compartment with a spacious sealed enclosure can easily accommodate your equipment, a tent and a dog.





PUNCH POWERGLIDE 6L50 6-SPEED AUTOMATIC TRANSMISSION GEARBOX

UAZ Pickup is equipped with PUNCH Powerglide 6L50 automatic transmission. The system represents the Powerglide family of products originally designed by General Motors. Now the gearboxes for UAZ vehicles, are manufactured by PUNCH Powerglide's Strasbourg factory in the northeast of France.

Powerglide 6L50 is a traditional six-speed automatic transmission with a torque converter clutch and a huge safety factor – maximum power and torque stand at 320 hp and 500 Nm respectively. The gearbox is paired with the updated ZMZ Pro engine with 149.6 hp and 235 Nm.

Powerglide 6L50 transmission is characterized by higher fuel economy. When cruising along the highway at a constant speed of 90 km/h, UAZ Pickup, equipped with AT, consumes 2 litres less fuel than the one with a manual gearbox.



Powerglide 6L50 by PUNCH Powerglide Strasbourg



Manual shift mode implies more accurate control of AT, demonstrates full engine power and imitates the operation of a manual gearbox with forced consecutive upshifts and downshifts when the lever is moved to the +/- positions.



DYMOS 5-SPEED MANUAL GEARBOX

The five-speed manual gearbox has also been upgraded. A team of UAZ engineers has improved the selectivity and reduced shift travels and lever pressing. The lever itself is now composite and features a damper that improves vibroacoustic comfort. Lower noise levels and reduced background vibration are another benefit of the installation of a new clutch by LUK, with the driven disk augmented with an idle damper. Clutch pedal force is now 20% lower due to the new clutch spring.



SPACIOUSNESS

SPACIOUS CARGO AREA

Whatever the task or job is, you can fit everything you need in the cargo compartment of the upgraded UAZ Pickup. There is no limitation on the shape of the items except for the capacity of the bed itself. The cargo compartment will easily accommodate even large items.



STYLE

MODERN PICKUP WITH OUTSTANDING FEATURES

The UAZ Pickup is a large vehicle for both cargo and passengers, and it stands out and attracts attention on the road. The revamped UAZ Pickup design is now more expressive and modern due to the new radiator grill and clear-cut lines that emphasise the confident personality of this safe and reliable vehicle.



New radiator grill with chrome-plated parts and enlarged chrome-plated UAZ logo



Body-coloured rear view mirrors with integrated directional signals



Headlamps with LED daytime running lights



Rear lights



COMFORT

The UAZ Pickup interior is designed to create a pleasurable experience in the vehicle. The upgraded UA Z Pickup has leather trim on the seats, steering wheel, and the new shift lever and parking-brake grips.

COMFORT ALL OVER

Now everyone can appreciate the new interior of the upgraded UAZ Pickup, with its key element being a new leather-trimmed steering wheel. For your comfort and increased safety on the move, the steering wheel now has new functions. And for your convenience, there are new modern steering column controls with expanded functions.



Newly designed right-hand steering column switch with intermittent windscreen wiper control



Second row seats with central armrest is also equipped with two high-capacity cup holders



Left-hand steering control switch in the new design with driving turn signal indicator mode and trip computer controls



Newly designed multi-function steering wheel with cruise control and speed limiter, multimedia and speaker systems



Refrigerated glove box with USB port

IMPROVED ERGONOMICS



7-inch multimedia touch-screen display with adjustable tilt angle is located at the same level as the revamped white instrument cluster, providing comfort and safety when driving



Power window and exterior mirror controls on the driver's door



Light control unit with improved activation algorithm



System controls on the central console



COMFORTABLE VEHICLE INTERIOR

The upgraded UAZ Pickup interior has been completely transformed: new leather-trimmed 3-spoke steering wheel and control of new functions, all with improved ergonomics! Seat and steering wheel adjustment provide maximum comfort for a long journey or a short trip in the city.

In the upgraded UAZ Pickup, both the angle and height of the steering wheel can be adjusted



VERSATILITY

THE UAZ PICKUP IS RELIABLE AND IRREPLACEABLE FOR ANY PURPOSE!

Whether you are going fishing with a pile of tackle or out on a serious hunt, taking a trip with a big group or delivering building materials in the countryside, the UAZ Pickup can do the job with its comfortable cabin and spacious cargo compartment.



SAFETY

The upgraded UAZ Pickup has modern equipment that gives the vehicle a new level of safety. Thanks to front airbags and safety belts with tensioners, every passenger will be safely protected in the upgraded UAZ Pickup.

Driver-side air bag in the steering wheel and front passenger air bag



Front safety belts with tensioners, force limiters and new height adjusters



ACTIVE SAFETY SYSTEMS IN THE UPGRADED UAZ PICKUP

For the first time, the UAZ Pickup has an electronic stability program, or ESP (along with ABS and EBD). The ESP was added to the UAZ Pickup in cooperation with the German company Bosch. The upgraded UAZ Pickup has a whole range of functions for increasing active safety.

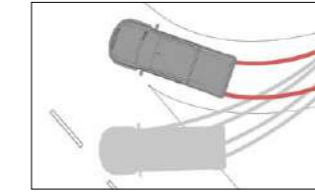

The ESP System

helps the car maintain its trajectory when there is an increased risk of skidding, slipping or rolling over. In the upgraded UAZ Pickup, ESP can be turned off with the touch of a button

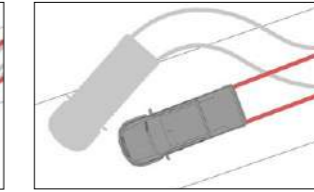

ABS

prevents wheel lock-up when braking to maintain the vehicle's stability and control and in most cases reduces the braking distance

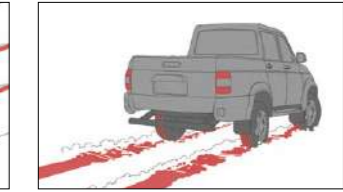

Off-road mode

is switched on by a special button on the central console for efficient braking on loose surfaces

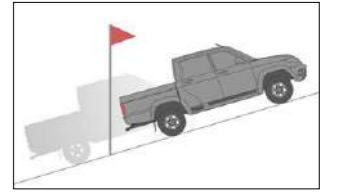

The Hill Hold Control System

keeps the vehicle on brake for several seconds while the driver moves his foot to the gas pedal, preventing the vehicle from rolling backward on a hill when the brake pedal is released

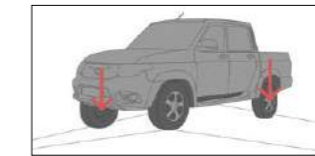

The traction control system (TCS)

provides electronic wheel differential gear locking, optimising the traction on the driving wheels

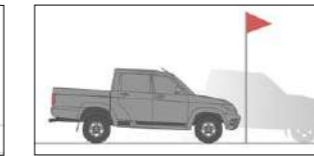

The hydraulic brake assist system (HBA)

engages during emergency braking to ensure a swift stop with a sharp but insufficient depression of the brake pedal

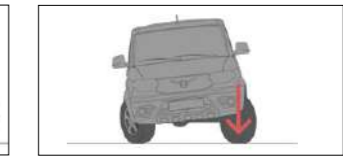

Cornering braking control (CBC)

distributes the brake force on each wheel when braking during a turn

FIT FOR ANY CLIMATE

MAXIMUM COMFORT

The UAZ Pickup is ready for extremely hot, moderately cold and exceptionally humid climate conditions. The upgraded UAZ Pickup has also a heated steering wheel rim.

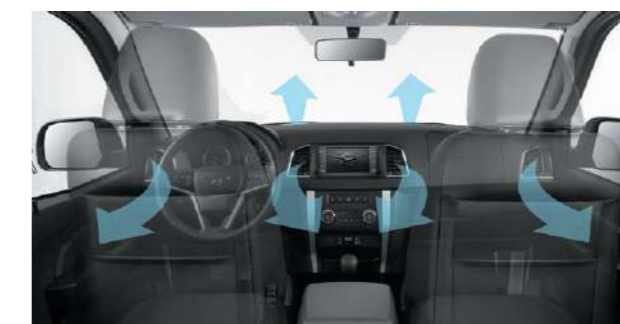

Modern air conditioning system with climate-control



Completely redesigned heating, fans and air conditioning system with climate control functions

FREEDOM OF CHOICE

IT'S ALL ABOUT MORE POSSIBILITIES

The upgraded UAZ Pickup has everything for transporting items needed at work or on holiday. The list of additional equipment includes a protective cover on the cargo compartment with gas springs, which will protect the load from bad weather and external impacts (volume 1181 l).

A hard-top canopy is also available for the cargo compartment, equipped with an additional stop signal, that can easily accommodate larger items and even a dog (the volume of the enclosure is 2243 l). Safety-bars on the cargo compartment help fasten cargo more securely, reinforce the structure and give the vehicle a more expressive look.



CONFIDENCE

For safe parking and improved convenience, the upgraded UAZ Pickup has front parking sensors and the image from the rear-view camera is supplemented with dynamic lines.

With this modern system it is easier to park the UAZ Pickup in small spaces.



Front parking sensors, which can be turned off, and wear-resistant fog lamps



Rear view camera in the handle of the tailgate



When backing up the vehicle, a color display shows the view from the rear camera with dynamic lines, as well as front and rear parking sensor signals

ADVANTAGES OF ORIGINAL ACCESSORIES

The personal safety of the driver and passengers depends on the quality of the vehicle parts. Original manufacturer's accessories meet all modern technical requirements.



Cargo compartment cover



Cargo compartment safety bars



Hard-top canopy



Winch



Towing coupler



Snorkel



INDEPENDENCE

GENUINE ALL-WHEEL DRIVE OFF-ROAD VEHICLE

The upgraded UAZ Pickup still has all the advantages of a first-class off-road vehicle able to reach even the most remote places in the country. Unmatched approach and departure angles, solid frame design, high road clearance and part-time all-wheel drive in lower gears. And as of 2016 these advantages are now joined by electronic rear differential locking.

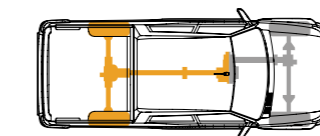
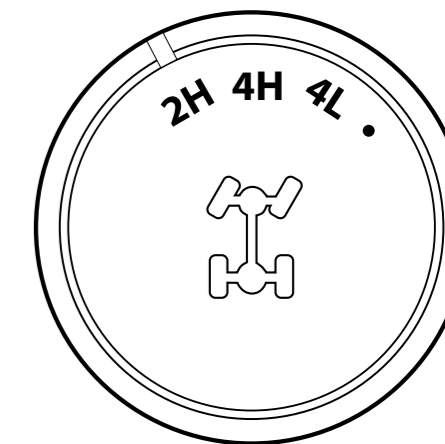

2H Rear-wheel drive
Torque is transmitted to the rear wheels, which saves fuel when driving on roads

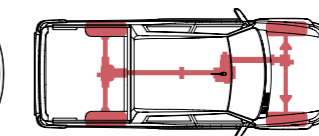

4H All-wheel drive
Part-time all-wheel drive brilliantly manages driving under difficult road and weather conditions

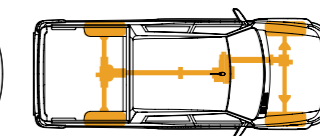

4L All-wheel drive and lower gear range
Lower gear input in the 2.542 transmission ratio gearbox, ideally suited for driving on the most rugged terrain

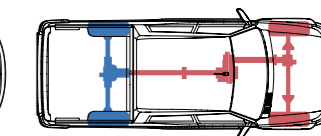

4L+ Rear axle differential lock
The Eaton rear axle differential lock is intended for maximising off-road driving parameters, and is switched on by a button in the cab

THE DESTINATION OF YOUR CHOICE

REAL BODY-ON-FRAME OFF-ROAD VEHICLE

The UAZ Pickup is made more stable vehicle by its extended wheel base, while the high road clearance makes it a genuine off-road vehicle. But it is also important to remember that the UAZ Pickup is a body-on-frame off-road vehicle. The strong ladder frame protects the body from

impacts as well as from the torsion and tensile loads that occur when driving on rough roads, pulling a heavy trailer or a stuck vehicle. This design helps prolong the life of the car even in most extreme operation conditions.

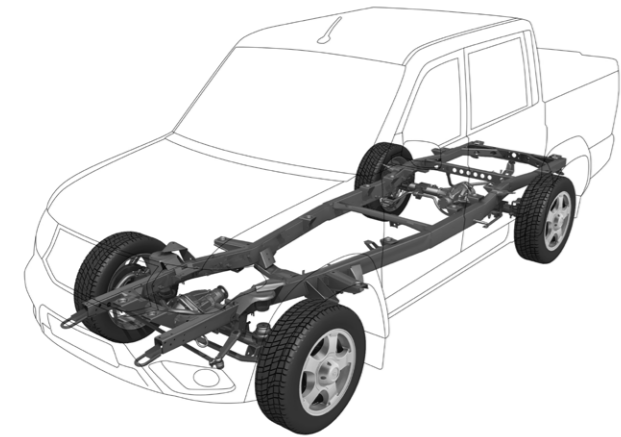

FRAME DESIGN FEATURES:

1. Impact protection
2. Torsion protection
3. Tensile protection
4. Proportional load distribution
5. Vehicle service life extension



BODY COLOURS



White non-metallic

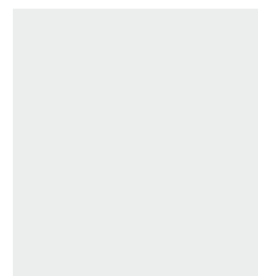

Silver metallic

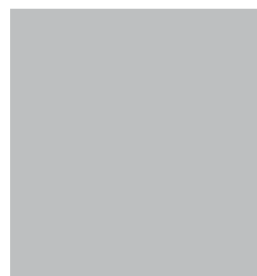

Brown metallic



Black metallic



Dark grey metallic



Dark green metallic



UPHOLSTERY & WHEEL DISCS

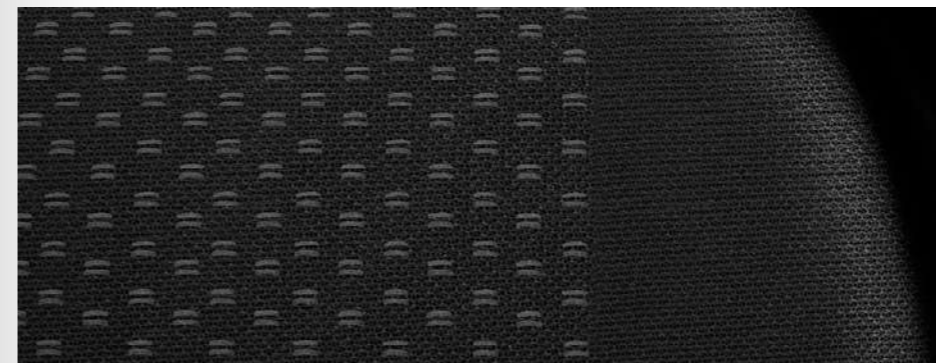

Dark fabric



Dark leather



16-inch steel wheels



16-inch light alloy wheels



16-inch light alloy wheels «Football»



POWER AND CAPACITY



PETROL ENGINE

The engine is reliable because of its proven design, and also stands out for its modest fuel consumption and resistance to off-road conditions. It is installed in all configurations of the vehicle and has high torque even at low speed, which helps the upgraded UAZ Pickup confidently take off on country roads and feel comfortable in the city.



DIESEL ENGINE

The diesel engine that sets the upgraded UAZ Pickup in motion was designed in collaboration with the leading foreign engineering companies. It has Common Rail system developed by the world-renowned brand BOSCH and variable valve timing with a chain drive, which helps considerably reduce maintenance costs.

ENGINE AND TRANSMISSION

ENGINE AND TRANSMISSION	ZMZ - 40906 Petrol engine	ZMZ - 51432 Diesel engine
Engine type and model	ZMZ - 40906 Petrol engine	ZMZ - 51432 Diesel engine
Fuel type	Petrol with octane no less than 92	Diesel
Capacity, l	2,693	2,235
Maximum output, hp (kW)	150 (99,0) a 4,600 rpm	113,5 (83,5) a 3500 rpm
Maximum torque, N m	217,0 at 3,900 rpm	270,0 a 1,800–2,800 rpm
Axle configuration	4×4	4×4
Gearbox	5-speed manual	
Transfer case	2-speed transfer case with electric drive (low gear working ratio $i = 2,542$)	
Drive type	Switchable all-wheel drive system (Part-Time)	
Emission standard	EURO 5	EURO 4
SPEED AND EFFICIENCY		
Maximum speed, km/h	140	135
Urban cycle, l/100 km	6,85	n/a
Extra-urban cycle (at 90 km/h), l/100 km	8,3	10,0
Fuel tank capacity, l	68	68

DIMENSIONS

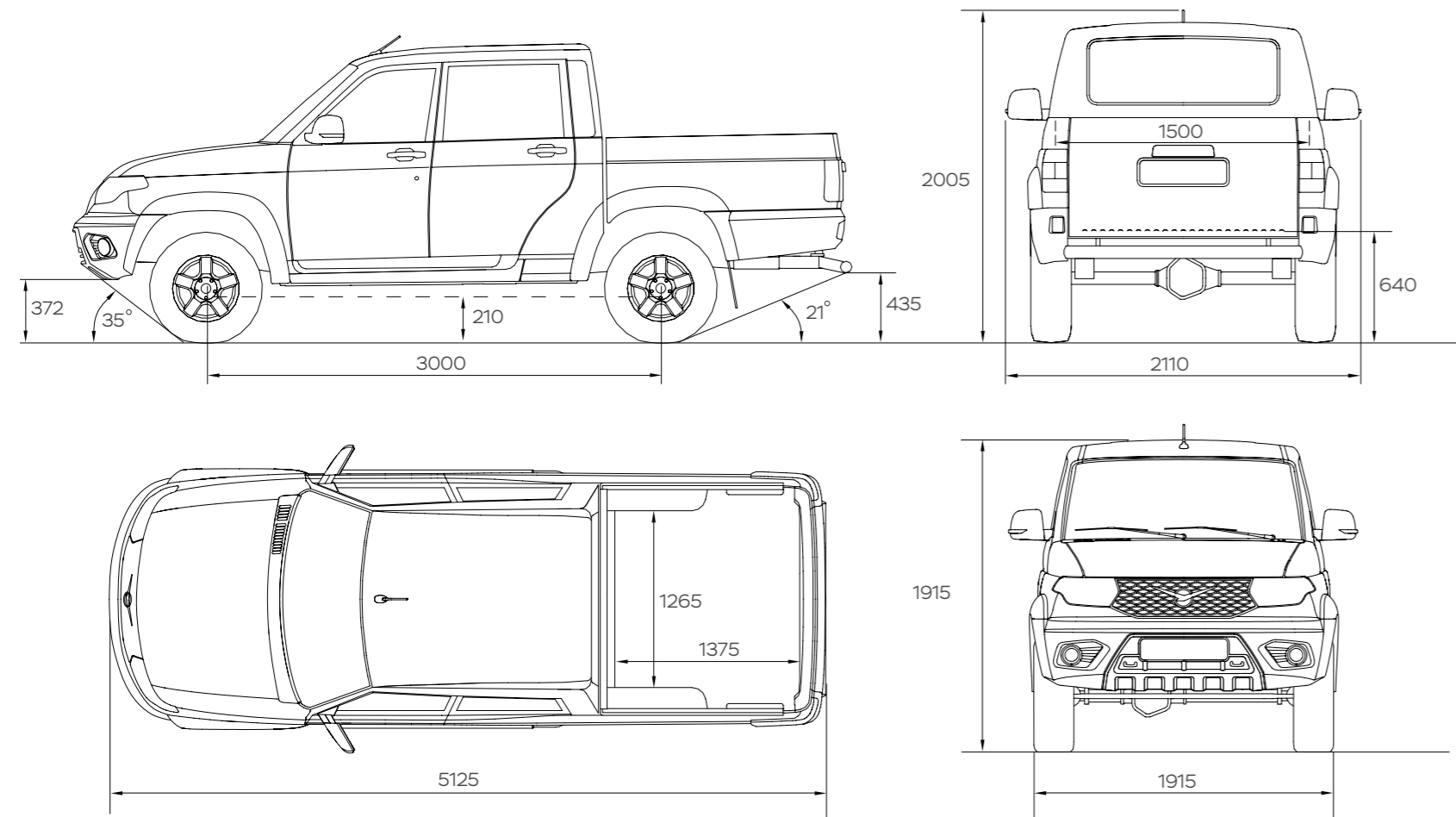

SPECIFICATIONS

UAZ PICKUP	
Vehicle model	23632
Vehicle type	Off-road vehicle (station wagon)
Passenger capacity, persons	4+1
Unladen weight, gasoline/diesel, kg	2070...2135
Full weight, gasoline/diesel, kg	2795...2860
Payload, kg	765...865
Max. front axle load, kg	1145...1230
Max. rear axle load, kg	1630...1650
Overall length, mm	5125
Overall width (without/over mirrors), mm	1915/2110
Overall height (without canvas cover/with canvas cover/with canopy/with antenna), mm	1915/1950/1975/2005
Wheelbase, mm	3000
Front track, mm	1600/1610
Rear track, mm	1600/1610
Volume of luggage compartment (with cover/ with canopy), l	1400/2700

ENGINE		
Model	ZMZ - 409051 Four-stroke. Gasoline.	ZMZ - 51432 Four-stroke. Diesel.
Number and arrangement of cylinders	4, in-line	4, in-line
Displacement, cm ³	2693	2235
Maximum output, kW (hp)	110 (150) at 5000 rpm	83.5 (113.5) at 3000 rpm
Maximum torque, Nm	235.4 at 2650 rpm	270 at 1300-2800 rpm
Fuel	92/95 gasoline	Diesel

TRANSMISSION		
Gearbox	5-speed manual	6-speed automatic
Transfer gearbox	Manual, 2-speed, direct-drive and underdriven	
	Single-lever control	Electromechanical drive control
Reduction gear ratio	1,940	2,480 / 2,542
Type of drive	4x4 with front-wheel drive activation option	

CHASSIS	
Front suspension	Dependent, spiral spring, with stabilizer bar
Rear suspension	Dependent, leaf, with stabilizer bar
Steering gear	Hydraulic power steering
Service brakes type (front axle / rear axle)	With ventilated disc mechanisms / with drum mechanisms
Wheel discs	6.5JX16H2 · 7JX16H2
Tires	225/75R16 · 235/70R16 · 245/70R16

SPECIFICATIONS	
Fuel tank capacity, l	68±2
Fuel consumption at driving with constant 90 km/h speed, gasoline/diesel, l	12/10
Max. speed, gasoline/diesel, km/h	150/135
Approach angle / departure angle, deg.	35/21
Min. road clearance, mm	210
Turning circle along the front outer wheel axis, m	6.02



A real SUV should adequately cope with any tests.

Modern technological solutions and the latest equipment from the world's leading manufacturers guarantee you absolute passage, with the highest level of comfort and safety of our cars.

For 75 years, our SUVs have repeatedly confirmed their outstanding product quality in extreme climates and challenging road conditions.

Hundreds of thousands of kilometers in the steppes of Central Asia, the mountains of Transcaucasia, across the deserts of Africa and the expanses of the Far North, and finally, the victorious ascent to the highest mountain in Europe – Elbrus, all have allowed our cars to become a symbol of overcoming any obstacles in the harshest of conditions.

UAZ. A symbol of passage. A mark of excellence.

UAZ.GLOBAL

